

Review of Higher Education in Ukraine

Overview of Ukraine's System of Education



The Ukraine's system of education is comprised of pre-school education, comprehensive secondary education, vocational technical education (VET in EU terminology) and higher education (pre-graduate, graduate); also there is a post-graduate research education system for science degrees obtaining: Candidate of Science, Doctor of Science (doctoral and post-doctoral education in EU terminology). The Ukrainian higher education system peculiarity is the inclusion of Specialist and Master Degree to the second cycle.

The major priorities in the development of the education sector, as defined by the Government of Ukraine, encompass: better quality of educational services for Ukrainian citizens; introduction of an independent external assessment of secondary school graduates; ensuring broader autonomy for universities providing for independent decision making on academic, research and financial issues; comprehensive support for science, research-and-development, including financial support for prominent universities and other research institutions as well as provision of the state-of-the-art equipment; improving the quality of textbooks for secondary school and higher education. (The system of education as of today is presented in Figure 1).

The Ukrainian system of education is managed by the Ministry of Education and Science of Ukraine; it directs and coordinates the operation of the education system through 24 regional education departments of regional state administrations, as well as education departments of the Autonomous Republic of Crimea, Kyiv and Sevastopol municipal state administrations.



The above regional departments coordinate and supervise education

units at the district or city level (second tier of local government) and further downward to the town or village level (third tier of local government). Local governments are in charge of pre-school and general secondary education; while public (state) universities deliver higher education services on a contractual basis. In addition, several line ministries maintain their own educational programs.

Higher Education in Ukraine



Ukraine has a vast and dynamic system of HEIs that is constantly transforming under the influence of internal and external factors.

Statistics Higher Education Institutions for 2009 (source: State Committee of Statistics):

Total number of HEI of different levels of accreditation and ownership	881
universities	196
academies	56
institutes	119
conservatory	1
colleges	228
technical schools	152
vocational schools	129

Among them:

State HEI	466
Private HEI	196
Communal HEI	219

HEI of III-IV Level of Accreditation (Bachelor, Specialist, Master)	353
State HEI	225
Private	113
Communal	15

HEI of I-II Level of Accreditation (Junior Specialist, Bachelor)	528
State HEI	241
Private	83
Communal	204

The total number of students studying at the Ukrainian Higher Education Institutions as for 2008/2009 academic year went beyond two million seven hundred thousand, among them more than one million six hundred thousand were full-time students.



Currently, the general trends are towards optimization of universities networks and quality enhancement: smaller universities with fewer faculty and staff have little chance to survive as they are unable to offer high quality education services. The pending draft law “On Amendments to the Law on Ukraine “On Higher Education” incorporates the modifications necessary for upgrading Ukraine’s higher education. It also highlights that all of the HEIs should become the scientific centers on fundamental

research. Over one academic year (2007-2008), 23 HEIs lost their licenses for higher education services (they were either shut down or had to merge with other universities, this contributing to the general trend of consolidation).

The strategic objectives set by the Ministry of Education and Science of Ukraine for the higher education sector include:

- developing the contemporary strategy for higher education development focusing on quality assurance and its integration with European and global higher education areas;
- developing the proper legal-regulatory basis for higher education sector and HEIs;
- monitoring and ensuring law enforcement by Ukrainian HEIs;
- improving access for disabled people to higher education and vocational training, assisting their adaptation and increasing employability;
- aligning higher education legislation with the requirements of Bologna process, specifically via development of National Qualifications Framework;
- facilitating university autonomy, students’ self-government, public involvement with university governance;
- initiating programs for nurturing talented youth, their academic development and career planning;
- developing legal-regulatory basis and initiating measures for increasing employability of university graduates.

Higher Education and Bologna Process

Ukraine joined the Bologna process in 2005. Since then, the Action Plan on Quality Assurance for Higher Education of Ukraine and its Integration into the European and World Educational Community for the period until 2010 has been approved; the amendments to the Law on Higher Education in accordance



with Bologna provisions and recommendations prepared (the new draft law submitted for the review of the Ukrainian Parliament (Verkhovna Rada); Ukraine has become a member of the European Quality Assurance Register; the draft Diploma Supplement was developed in the EU/CoE/UNESCO format with the guidelines; the Task Force for the Development of the National Qualifications Framework for Higher Education has been set and launched consultation process; the Bologna Follow-Up Group was established.

As an active participant of Bologna process, Ukraine recognizes the broad transformed mission of higher education and the role it has to play under globalization, transfer to knowledge economy, rapid technological developments and demographic crisis. To adjust to the new challenges, to become the engines of innovations and change, Ukrainian universities have to embark on modernization and rigorous reforms. Modernization and reforms are aligned with Bologna process.

Significant progress has been achieved on three strategic paths of Bologna process: implementation of three-cycle degree system; quality assurance of higher education; recognition of diplomas and previous periods of study. The transfer to the first and second cycle has been implemented; the

preparation for the third cycle is under way. The national system of quality assurance has been upgraded. The implementation of the ECTS is completed in the first and second cycles.

Yet, there is a lot to be done in the near future. The upcoming challenges include:

- further development of provision of equal access to higher education;
- introduction of the innovative institutional structure,
- completion of a three-cycle system and joint / double degrees;
- aligning university curricula with Bologna structure;
- curricula reform with a view to the needs of employers;
- creating mechanisms for recognition of prior learning;
- increasing outward and inward mobility;
- development of the national qualifications framework for lifelong learning compatible with the EHEA overarching framework;
- creation of the national quality assurance agency;
- establishing programmes for foreign students and further internationalization of Ukraine's higher education.

(For more details see Bologna Process National Report: 2007-2009)

Among other achievements of modernization – expansion of University autonomy. Five Ukrainian universities: Kyiv National Taras Shevchenko University, National Yaroslav Mudry Law Academy, Lviv National Ivan Franko, University Kyiv Mohyla Academy and Ostroz'ka Academy have obtained the status of self-governing academic institutions as well as research centers; for other universities more autonomy is revealed through more involvement in the decision-making process with regard to curricula improvement, number of students and faculty, awarding scientific degrees and honours.

Other Developments in the System of Higher Education

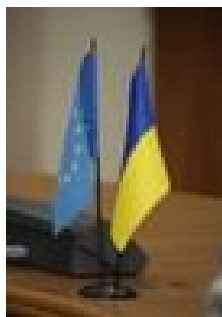

A lot of attention is being paid to the professional development of cadre for higher education; 115 post-graduate institutions (“aspirantura”) and 85 doctoral institutions (“doctorantura”) train academic and research staff. There are more opportunities for students to be involved in research projects; students’ participation in academic deliberations increased in 2007-2008 academic year: 3882 students’ academic papers were sent for national and international contests; 3 international forums, 161 international and 90 all-Ukrainian conferences, 21 seminars were hosted by Ukrainian universities.

Ukraine is persistently moving towards internationalization of its higher education: by the year 2009, 127 international agreements on cooperation in the field of education and science have been concluded with more than 70 countries; among them intergovernmental agreements with 22 states on the recognition of diplomas and degrees. About 100 similar agreements are currently being negotiated with international partners. Ukrainian researchers participate in more than 300 international research projects; 43 thousand international students from 133 countries of the world studied in Ukrainian universities in 2008; increasing participation of Ukrainian students in international intellectual contests (Olympiads).

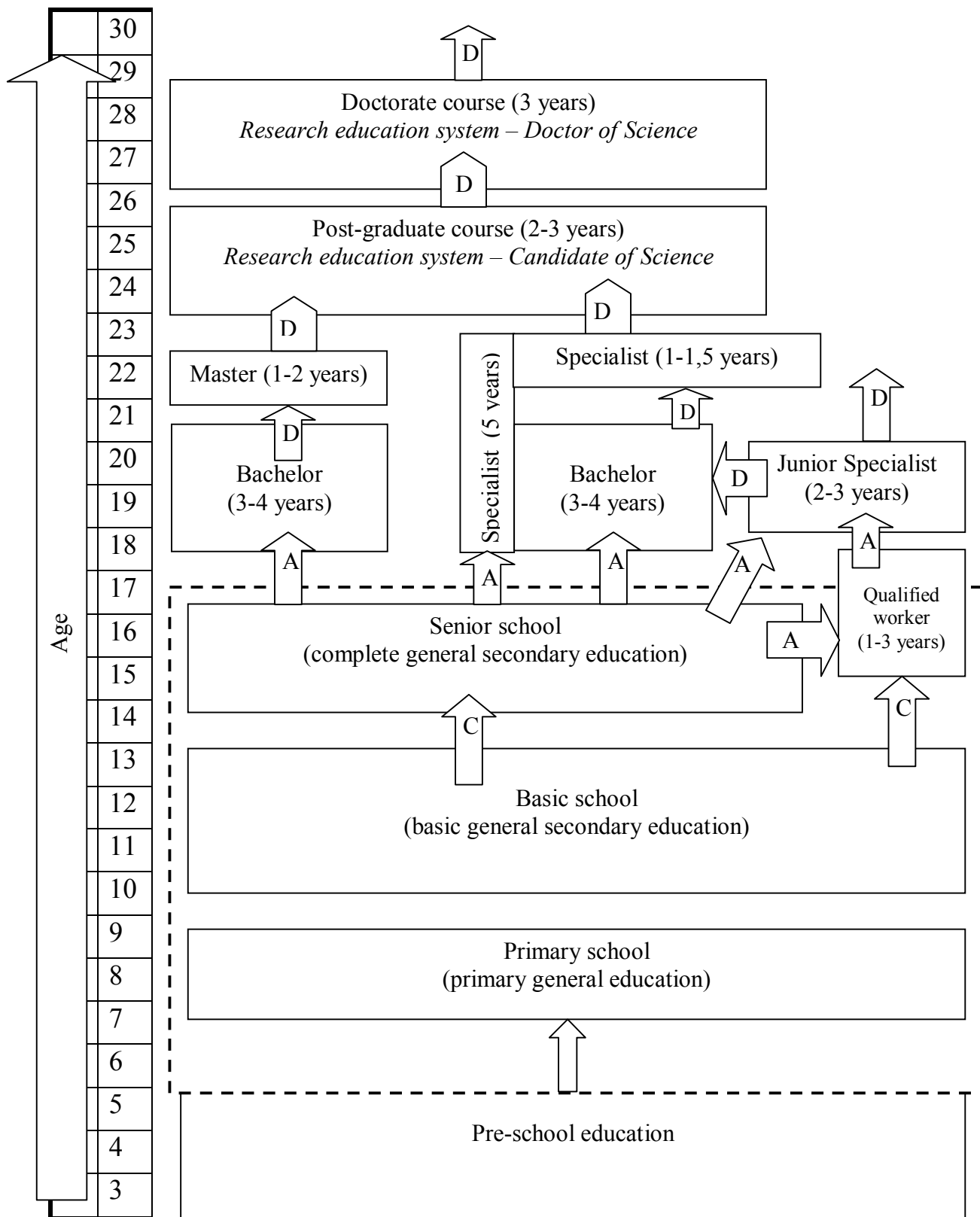

Note: C – Certificate A – Attestation D – Diploma (higher education)
(School-leaving certificate)

Fig.1. The structure of the system of education in Ukraine at present. (source: “Principal trends of modernization of higher education structure in Ukraine”, 2008, I.Vakarchuk, V.Shynkaruk, J.Boliubash), published by National Pedagogical University named after M.Dragomanov, 2008).

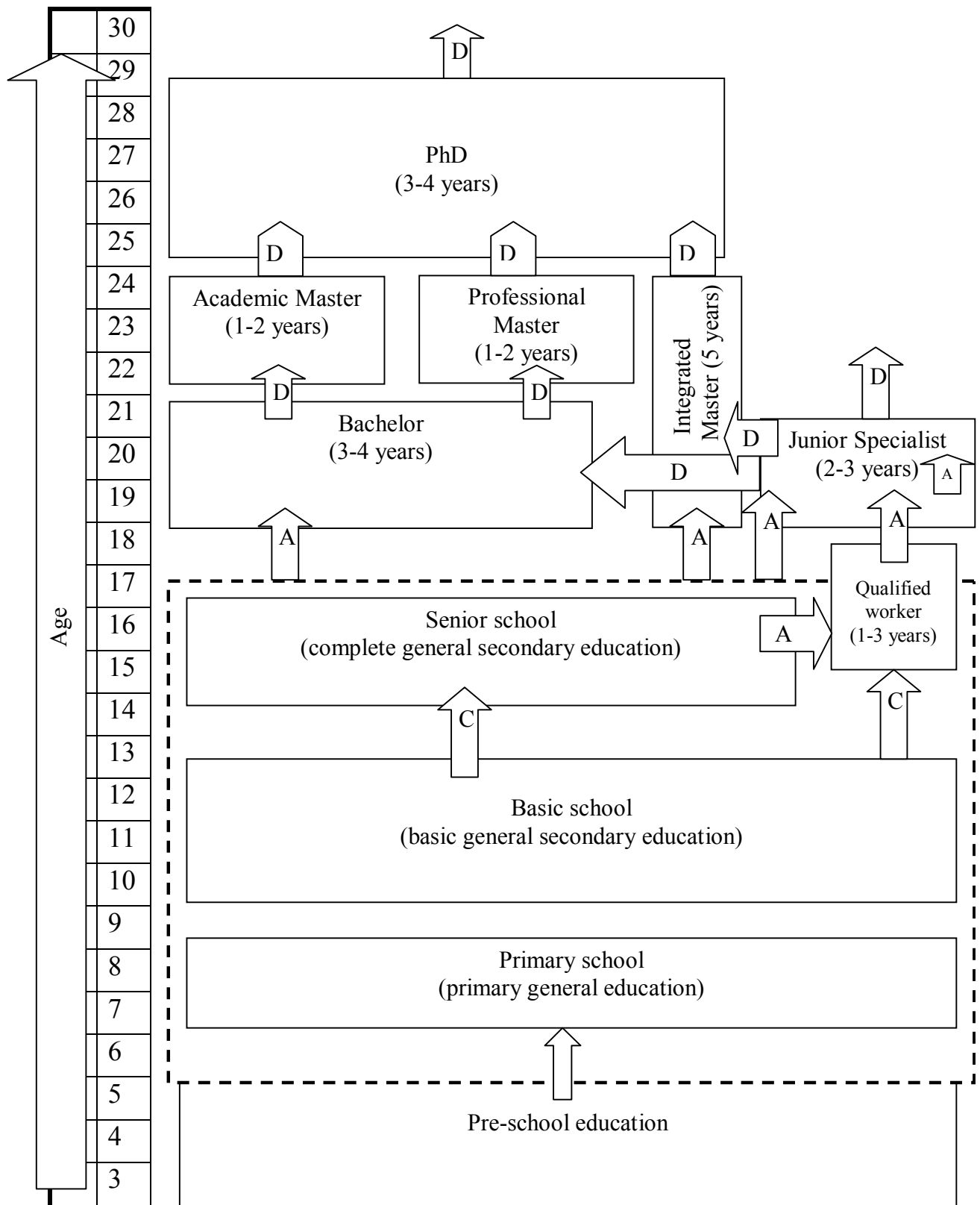

Note: C – Certificate A – Attestation D – Diploma (higher education)
 (School-leaving certificate)

Fig. 2. Modernization of the structure of the system of education in Ukraine in accordance with the EHEA requirements. (source: "Principal trends of modernization of higher education structure in Ukraine", 2008, I.Vakarchuk, V.Shynkaruk, J.Boliubash), published by National Pedagogical University named after M.Dragomanov, 2008).